

REVISION RECORD			
LTR.	CHANGES	BY	DATE
A	REDRAWN AND RELEASED	D. B.	11/18/11

D' SHANNON PRODUCTS, LTD

INSTALLATION MANUAL

B6300D REV. A

STC SA1471CE

BEECH GAP SEALS

INSTALLATION DRAWINGS AND INSTRUCTIONS

HAWKER BEEHCRAFT MODELS:

BARON WITH LONG CHORD FLAPS:

95, B95, B95A, D95A, E95, 95-55, 95-A55

95-B55 AND 95-B55A (S/N TC-371 - TC-1409 ONLY)

95-B55B (T-42), 95-C55, 95-C55A, D55, D55A, 56TC, A56TC,

E55 AND E55A (S/N TE-768 - TE-851 ONLY)

58 AND 58A (S/N TH-1 - TH-220 ONLY)

D' SHANNON PRODUCTS, LTD

800-291-7616, INT'L 763-559-5998

NEXT ASSY: DRAWN BY: D. B. ENGINEER: D. BRAUN CHECKED BY: D. B.		COVER SHEET	
<u>TOLERANCES</u> X_.10 .XXX_.01 XX_.03 .XXX_.001 ANGLES ±5% UNLESS STATED		<i>D' SHANNON PRODUCTS, LTD</i>	
DWG. No.	B6300D-1	REVISION	A
SCALE: NONE	DATE 11/18/11	SH	1 OF 1

REVISION RECORD			
LTR.	CHANGES	BY	DATE
A	RELEASED WITH NEW REVISION	D. B.	11/18/11

NUMERICAL DRAWING LIST CONTROL

DWG. No.	DATED	REV.	No. SHTS	EFF. ED	ED	ED	ED	DESCRIPTION
B6300D-1	11/18/11	A	1					COVER SHEET
B6300D-2	11/18/11	A	1					NUMERICAL DWG. LIST
B6300D-3	11/18/11	A	1					GENERAL NOTES
B6300D-4	11/18/11	A	1					PARTS LIST AND TOOLS
B6300D-5	11/18/11	A	20					INSTALLATION GAP SEALS

NEXT ASSY: DRAWN BY: D. B. ENGINEER: D. BRAUN CHECKED BY: D. B.	NUMERICAL DRAWING LIST		
<u>TOLERANCES</u> X_.10 .XXX_.01 XX_.03 .XXXX_.001 ANGLES ±5% UNLESS STATED	<i>D' SHANNON PRODUCTS, LTD</i>		
DWG. No.	B6300D-2	REVISION	A
SCALE: NONE	DATE 11/18/11	SH	1 OF 1

REVISION RECORD			
LTR.	CHANGES	BY	DATE
A	RELEASED W/CHGS TO NOTE 2 AND 5	D. B.	11/18/11

9. COMPLETE FAA FORM 337 AND REVISE THE AIRCRAFT'S WEIGHT AND BALANCE. WEIGHT 2.5 LB @ F. S. 120
8. SHOULD ANY OF THE GAP SEAL PARTS REQUIRE FINISHING, CLEAN AND WASH THE PARTS WITH PHOSPHORIC ACID PRIOR TO PAINT APPLICATION. ALL SURFACES MUST BE CLEAN AND DRY. APPLY ONE COAT OF DUPONT VARIPRIMER 615S OR EQUIVALENT. IF IT BECOMES NECESSARY TO REPLACE ANY OF THE TEFLON TAPE BECAUSE IT IS DAMAGED OR MISSING USE 3M SCOTCH 5491 PTFE FILM TAPE OR EQUIVALENT. USE THIS TAPE WHERE THE FACE OF THE SEAL COMES INTO CONTACT WITH THE FUSELAGE, AILERON OR FLAP. MAKE CERTAIN PROPER ADHESION IS ACHIEVED OR EQUIVALENT METHOD.
7. DO NOT APPLY FINISH PAINT TO THE TEFLON TAPE SURFACE WHEN PAINTING THE AIRCRAFT. THE INSTALLER WILL NOTE THE FOLLOWING WARNING IN THE FRONT INSIDE COVER OF THE AIRCRAFT LOGBOOK:

WARNING: DURING PAINTING DO NOT APPLY PAINT TO THE TEFLON TAPE ON THE CONTROL SURFACE SIDE OF THE AILERON FLAP GAP SEALS.
6. THE AIRCRAFT'S BATTERY HAS TO BE FULLY CHARGED WITH A BATTERY CHARGER ATTACHED TO THE BATTERY AND OPERATING. THE REASON FOR THIS IS THAT THE TRAVEL OF THE FLAP IS FURTHER WITH HIGHER VOLTAGE ON THE MOTOR.
5. ALL WORKMANSHIP SHALL BE ACCOMPLISHED USING ACCEPTED MECHANICAL PRACTICES. COMPLIANCE TO FAA ADVISORY CIRCULAR AC43.13-1B, OR LATER FAA APPROVED STANDARD AIRCRAFT PRACTICES.
4. IT IS IMPERATIVE FOR MAXIMUM PERFORMANCE OF THIS MODIFICATION THAT AILERONS AND FLAPS ARE CORRECTLY RIGGED. IF A DOUBT EXISTS BEFORE THE BEGINNING OF THIS INSTALLATION, CHECK THE RIGGING, FLAP TRAVEL, BALANCE OF AILERONS AND OVERALL CONDITION OF THE CONTROL SURFACES. REPAIR OR REPLACEMENT REQUIREMENTS SHOULD BE FULFILLED AT THIS TIME.
3. DURING AND AFTER THIS INSTALLATION, CHECK THE AILERON AND FLAP TRAVEL FOR COMPLETE UNIMPEDED OPERATION SUCH AS THAT ANY POTENTIAL CONTROL HANG-UPS, AND/OR PREMATURE SURFACE SKIN WEAR IS PREVENTED.
2. SEE HAWKER BEECHCRAFT SHOP MANUAL FOR AILERON REMOVAL AND INSTALLATION.
1. PRIOR TO INSTALLATION SEE SUPPLEMENTAL TYPE CERTIFICATE INCLUDED IN THE INSTALLATION PACKAGE TO MAKE SURE THAT THE AIRCRAFT IS COVERED BY THE STC. ALL GAP SEAL PARTS CAN BE POSITIVELY IDENTIFIED BY AN ADHESIVE LABEL CONTAINING THE PMA HOLDER'S IDENTIFICATION, PART NUMBER, SERIAL NUMBER (WHEN APPLICABLE) AND ELIGIBLE MODELS. .

NOTES:

NEXT ASSY: DRAWN BY: D. B. ENGINEER: D. BRAUN CHECKED BY: D. B.		GENERAL NOTES	
<u>TOLERANCES</u> X_.10 .XXX_.01 XX_.03 .XXX_.001 ANGLES ±5% UNLESS STATED		<i>D' SHANNON PRODUCTS, LTD</i>	
DWG. No.	B6300D-3	REVISION	A
SCALE: NONE	DATE 11/18/11	SH	1 OF 1

REVISION RECORD			
LTR.	CHANGES	BY	DATE
A	RELEASED W/ CLARIFIED CHERRY MAX GUN NOTE	D. B.	11/18/11

GAP SEAL PARTS LIST AND TOOLS

PARTS NOT SUPPLIED:

AN470AD4-4 RIVETS

AD44H ----- RIVETS

CHERRY MAX RIVETS (IF NEEDED)

TOOLS REQUIRED:

PHILIPS SCREW DRIVER

SCREW GUN OR DRILL

DRILL BITS: #21, #27, #30, #40

CLECOS: #30 AND #40

HAND RIVETER: FLAT HEAD #30 AND #40

POP RIVET GUN

COUNTERSINK CUTTER (100 DEG.)

MINI VAC OR BLOWER

METALLIC SCALE (FLEXIBLE AND STRAIGHT EDGE, 12 IN. PREFERABLY)

PENCIL

IF NEEDED, A CHERRY MAX GUN FOR CUSTOMER SUPPLIED CHERRY MAX RIVETS, OR A VERY GOOD POP RIVET GUN WILL ALSO WORK.

NEXT ASSY: DRAWN BY: D. B. ENGINEER: D. BRAUN CHECKED BY: D. B.		PARTS LIST AND TOOLS	
<u>TOLERANCES</u> X_.10 .XXX_.01 XX_.03 .XXX_.001 ANGLES ±5% UNLESS STATED		<i>D' SHANNON PRODUCTS, LTD</i>	
		DWG. No. B6300D-4	REVISION A
		SCALE: NONE	DATE 11/18/11 SH 1 OF 1

REVISION RECORD			
LTR.	CHANGES	BY	DATE
A	REDRAWN & RELEASED MOVED NOTES TO SHEETS	D. B.	11/18/11
	CLARIFY NOTES 8, 12, 18 AND 27		
	ITEM 8 AFT RIVET LINE DIM. <NOW> 1.2'		
	<WAS> 1.7' IN NOTE 24 AND DWG SHT 19		

15	<CUSTOMER SUPPLIED>	A. R.	CR3242-4-02	FLUSH HD CHERRY MAX.
14	<CUSTOMER SUPPLIED>	A. R.	MS204427-3-2	UNIVERSAL COUNTERSUNK RIVET
13	SHEET 19	A. R.	AN470AD3-3	UNIVERSAL HEAD RIVET
12	SHEET 4	A. R.	5491	SCOTCH BRAND TAPE
11		A. R.	_____	ORIGINAL HARDWARE
10	SHEET 14, 16, 17, 18, 19	A. R.	AD44H	POP RIVET
9	SHEET 13, 20	A. R.	AN470AD4-4	UNIVERSAL HEAD RIVET
8	SHEET 2, 3, 19, 20	2	B6304	AILERON GAP SEAL
7	SHEET 2	1	B6301-2	WING BOLT FAIRING EXT. PL <RH>
6	SHEET 2, 3, 18	1	B6301-1	WING BOLT FAIRING EXT. PL <LH>
5	SHEET 2, 3, 15, 16, 17, 18, 19	3	B6305	FLAP GAP SEAL
4	SHEET 14	1	B6303L-2	INBOARD TOP GAP SEAL FLAP <RH>
3	SHEET 14	1	B6303L-1	INBOARD TOP GAP SEAL FLAP <LH>
2	SHEET 2, 4,	1	B6302L-2	BOTTOM FLAP ROOT SEAL <RH>
1	SHEET 2, 3, 4, 6, 8, 9, 10, 11, 12, 13, 18	1	B6302L-1	BOTTOM FLAP ROOT SEAL <LH>
ITEM	LOCATION OF ITEMS	QTY.	PART NUMBER	D E S C R I P T I O N

NEXT ASSY: DRAWN BY: D. B. ENGINEER: D. BRAUN CHECKED BY: D. B.	INSTALLATION GAP SEALS		
<u>TOLERANCES</u> X_.10 .XXX_.01 XX_.03 .XXX_.001 ANGLES ±5% UNLESS STATED	D' SHANNON PRODUCTS, LTD		
DWG. No. B6300D-5	REVISION	A	
SCALE: NONE	DATE 11/18/11	SH	1 OF 20

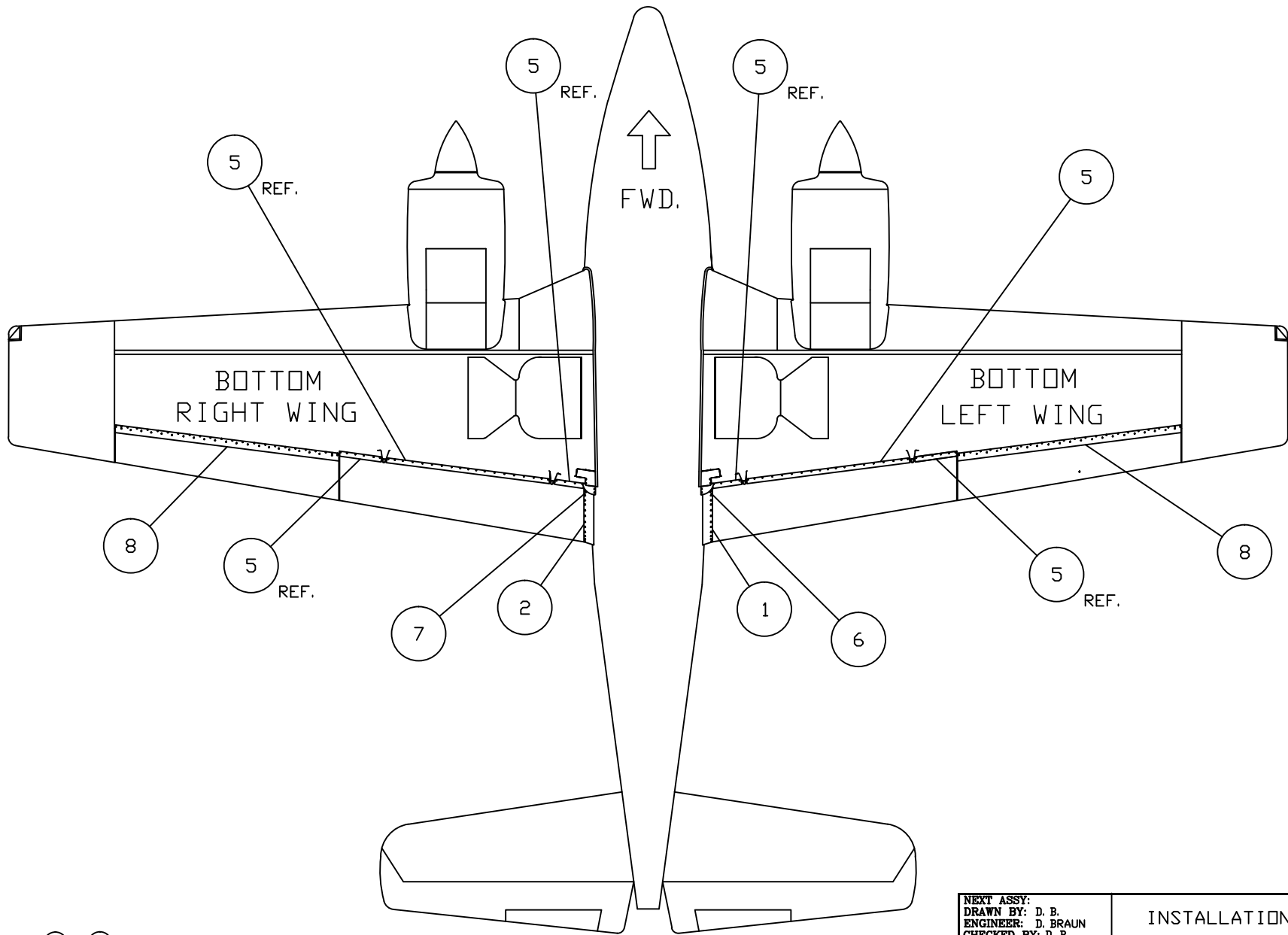

ITEMS ③ & ④ NOT SHOWN
ARE ON TOP OF FLAP

NOTES:

NEXT ASSY:
DRAWN BY: D. B.
ENGINEER: D. BRAUN
CHECKED BY: D. B.

INSTALLATION GAP SEALS

TOLERANCES
X_.10 .XXX_.01
XX_.03 .XXX_.001
ANGLES ±5%
UNLESS STATED

D' SHANNON PRODUCTS, LTD

DWG. No.	B6300D-5	REVISION	A
SCALE: NONE	DATE 11/18/11	SH	2 OF 20

BOTTOM VIEW OF WING

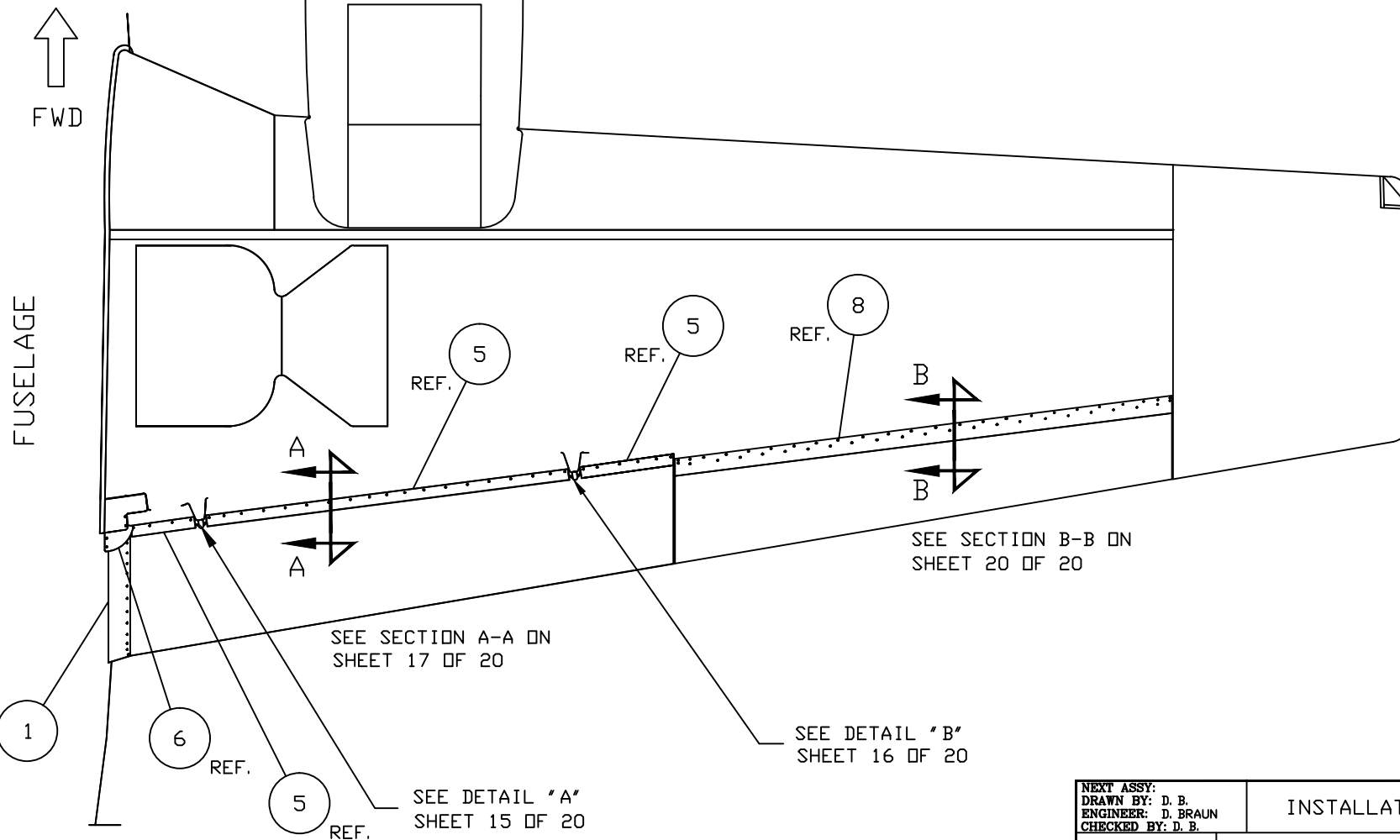

SEE SECTION A-A ON SHEET 17 OF 20

SEE SECTION B-B ON SHEET 20 OF 20

SEE DETAIL "A" SHEET 15 OF 20

SEE DETAIL "B" SHEET 16 OF 20

REF.

REF.

REF.

REF.

REF.

REF.

NEXT ASSY:
DRAWN BY: D. B.
ENGINEER: D. BRAUN
CHECKED BY: D. B.

INSTALLATION GAP SEALS

TOLERANCES
X_.10 .XXX_.01
XX_.03 .XXX_.001
ANGLES ±5%
UNLESS STATED

D' SHANNON PRODUCTS, LTD

DWG. No.	B6300D-5	REVISION	A
SCALE:	NONE	DATE	11/18/11
		SH	3 OF 20

NOTES:



PENCIL LINE

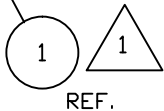

TEFLON TAPE

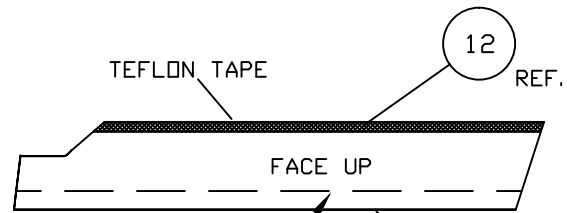
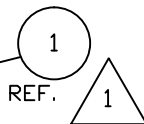

TEFLON TAPE

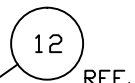

PENCIL LINE

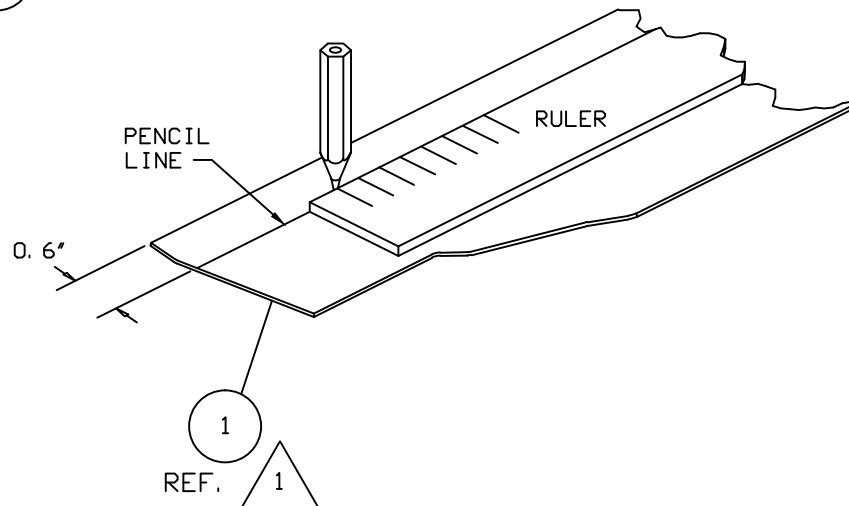
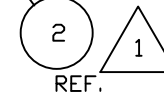
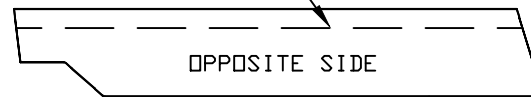

PENCIL LINE

RULER

0.6"



① ON THE FLAT SIDE OF ITEMS ① AND ② DRAW A PENCIL LINE 0.6" (+/-) 0.1" FROM THE FORWARD SMALLEST EDGE TO THE SMALL REAR EDGE ON BOTH SIDES. THIS LINE WILL REPRESENT THE RIVET LINE DURING INSTALLATION.

NOTES:

NEXT ASSY:
DRAWN BY: D. B.
ENGINEER: D. BRAUN
CHECKED BY: D. B.

INSTALLATION GAP SEALS

TOLERANCES
X_.10 .XXX_.01
XX_.03 .XXX_.001
ANGLES ±5%
UNLESS STATED

D'SHANNON PRODUCTS, LTD

DWG. No.	B6300D-5	REVISION	A
SCALE: NONE	DATE 11/18/11	SH	4 OF 20

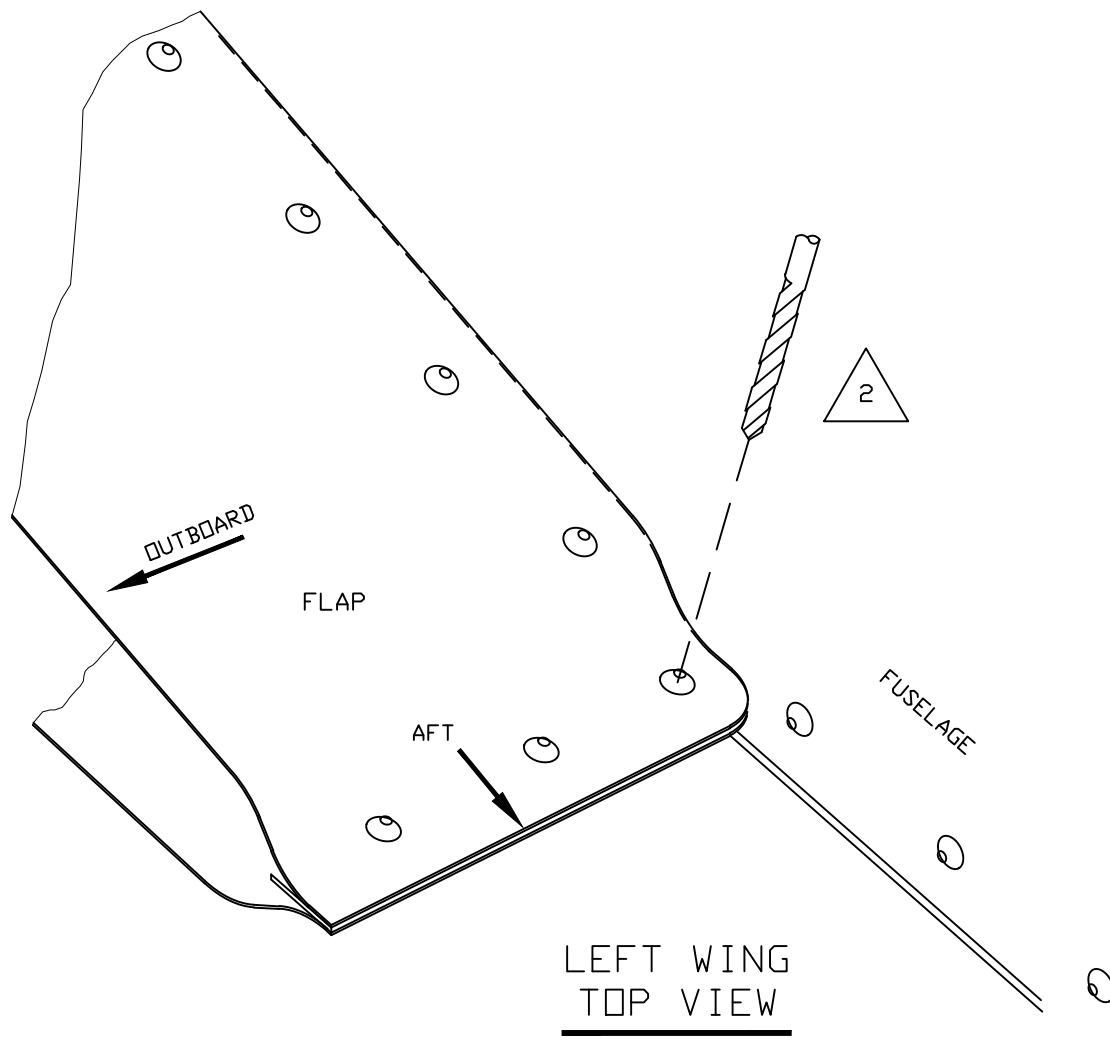

LEFT WING
TOP VIEW

2

DRILL OUT THE LAST RIVET AT THE LOWER BOTTOM TRAILING EDGE OF THE FLAP. USE A #30 DRILL BIT.

NOTES:

NEXT ASSY:
DRAWN BY: D. B.
ENGINEER: D. BRAUN
CHECKED BY: D. B.

INSTALLATION GAP SEALS

TOLERANCES
X_.10 .XXX_.01
XX_.03 .XXX_.001
ANGLES ±5%
UNLESS STATED

D' SHANNON PRODUCTS, LTD

DWG. No.	B6300D-5	REVISION	A
SCALE: NONE	DATE 11/18/11	SH	5 OF 20

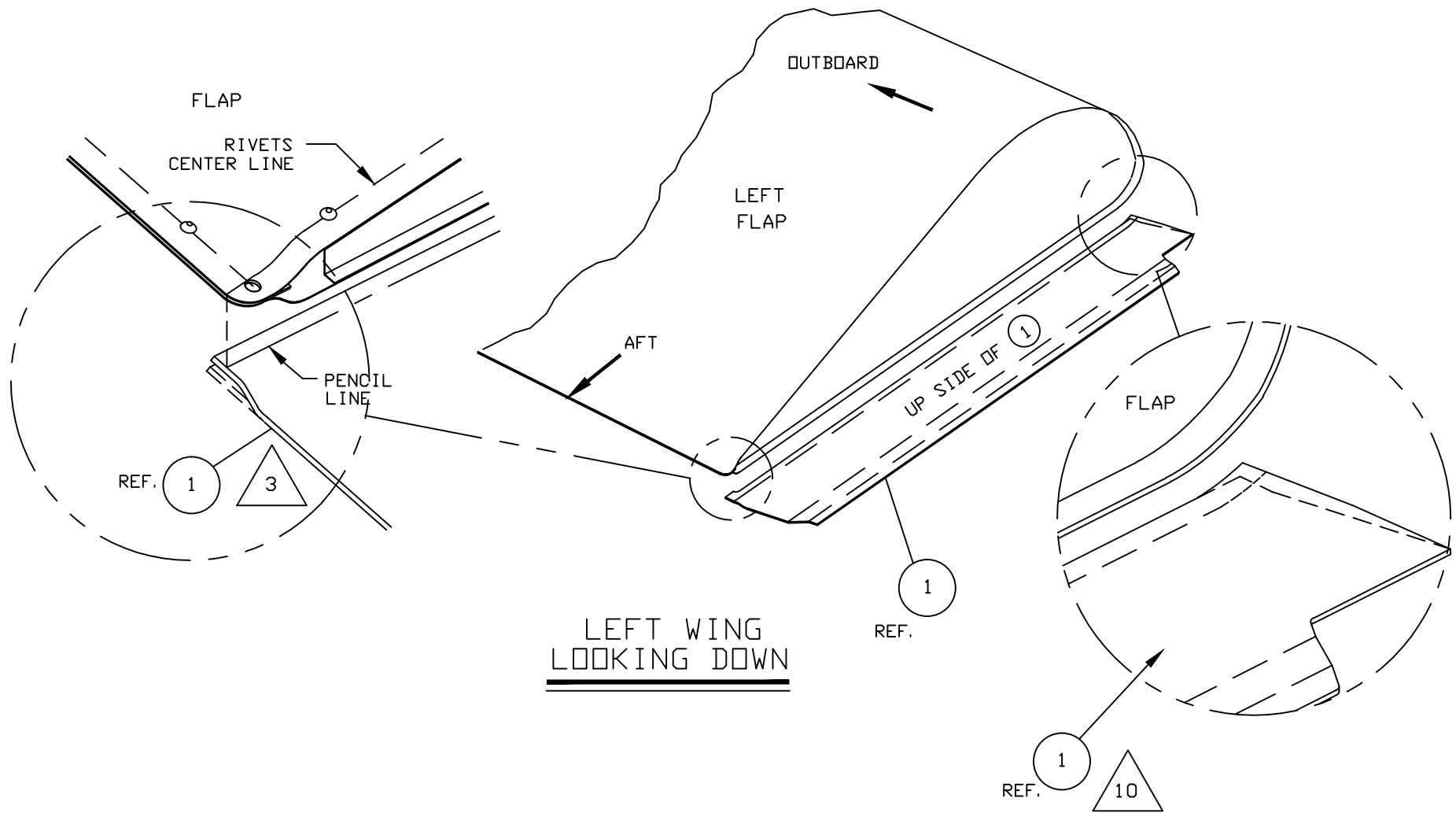

LEFT WING
LOOKING DOWN

△10 AFTER ALL HOLES HAVE BEEN DRILLED, CHECK TO SEE IF THE FORWARD EDGE OF ITEMS ① AND ② CLEAR THE AFT WING SKIN BY 0.1". IF NECESSARY TRIM ITEMS ① END ② TO GAIN CLEARANCE. CLECD IN PLACE AND HAND FORM FOR PROPER FIT. HAND FORMING IS CRITICAL TO MAKE SURE THERE IS NO PRESSURE FROM ITEMS ① AND ② AGAINST THE FUSELAGE. CAUTION: EXCESS PRESSURE COULD CAUSE FLAP COMPONENT STRAIN AND MOTOR BURNOUT.

△3 JOGGLE THE AFT ENDS OF ITEMS ① AND ② SO THEY MATCH THE CONTOUR OF THE BOTTOM TRAILING EDGE OF THE FLAPS. FORM THE FORWARD ENDS OF ITEMS ① AND ② SO THAT THEY MATCH THE CONTOUR OF THE LEADING EDGE OF THE FLAPS.

NOTES:

NEXT ASSY: DRAWN BY: D. B. ENGINEER: D. BRAUN CHECKED BY: D. B.		INSTALLATION GAP SEALS	
TOLERANCES X_.10 .XXX_.01 XX_.03 .XXX_.001 ANGLES ±5% UNLESS STATED		D' SHANNON PRODUCTS, LTD	
DWG. No.	B6300D-5	REVISION	A
SCALE: NONE	DATE 11/18/11	SH	6 OF 20

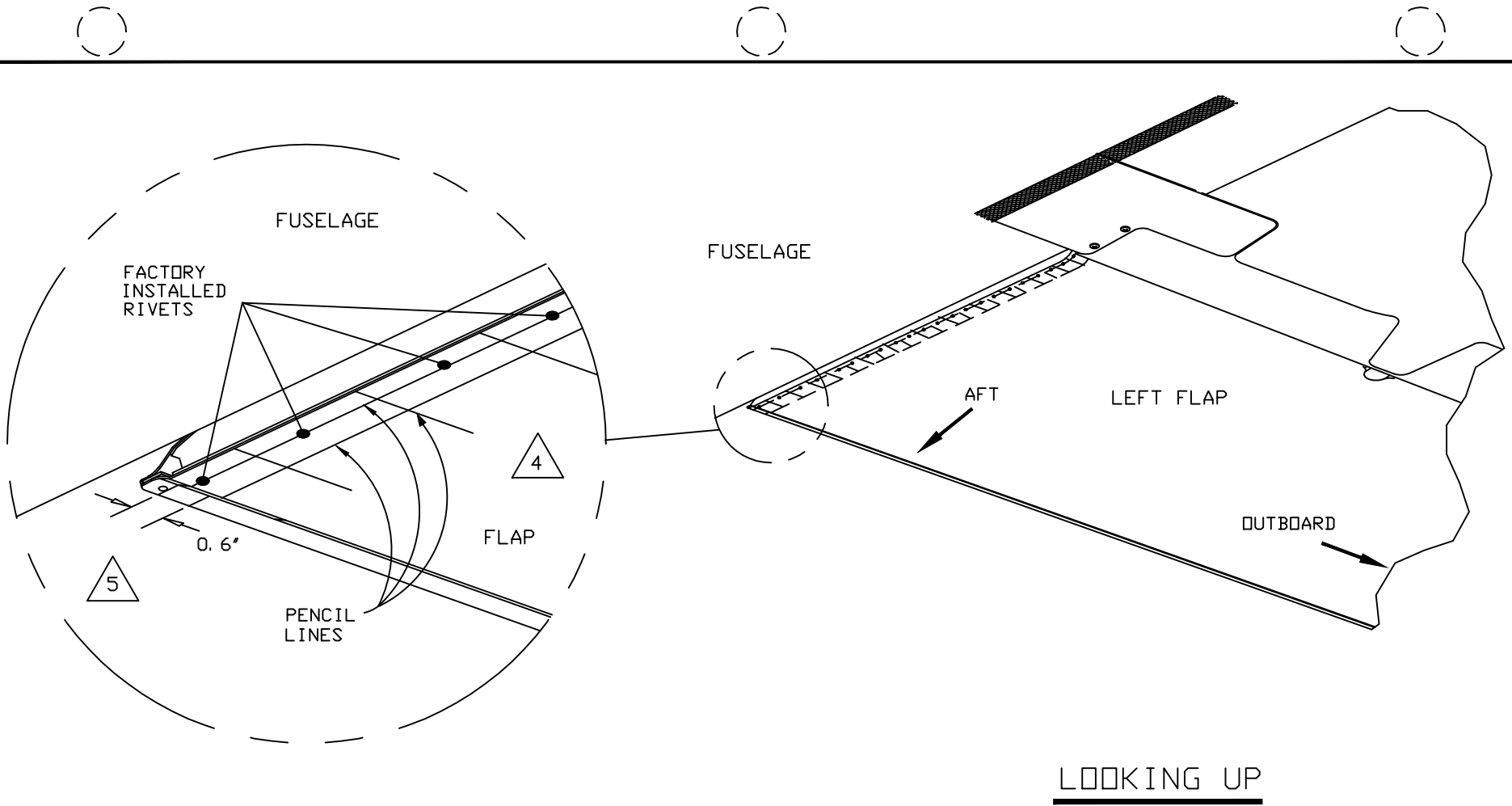

LOOKING UP

- △5 NEXT, DRAW A LINE CONNECTING THE RIVETS ON THE INBOARD BOTTOM OF THE FLAP. DRAW A SECOND LINE EXACTLY 0.6" PARALLEL TO THE RIVET LINE YOU HAVE JUST DRAWN. THIS SECOND LINE WILL ACT AS A GUIDE WHEN INSTALLING ITEM ① AND ② .
- △4 DRAW, ON THE BOTTOM OF THE FLAPS, 2" TO 3" PENCIL LINES INBOARD TO OUTBOARD BETWEEN EACH OF THE FACTORY RIVETS LOCATED ON THE INBOARD FLAP END RIB.

NOTES:

NEXT ASSY: DRAWN BY: D. B. ENGINEER: D. BRAUN CHECKED BY: D. B.		INSTALLATION GAP SEALS	
<u>TOLERANCES</u> X_.10 .XXX_.01 XX_.03 .XXX_.001 ANGLES ±5% UNLESS STATED		<i>D' SHANNON PRODUCTS, LTD</i>	
DWG. No.	B6300D-5	REVISION	A
SCALE: NONE	DATE 11/18/11	SH	7 OF 20

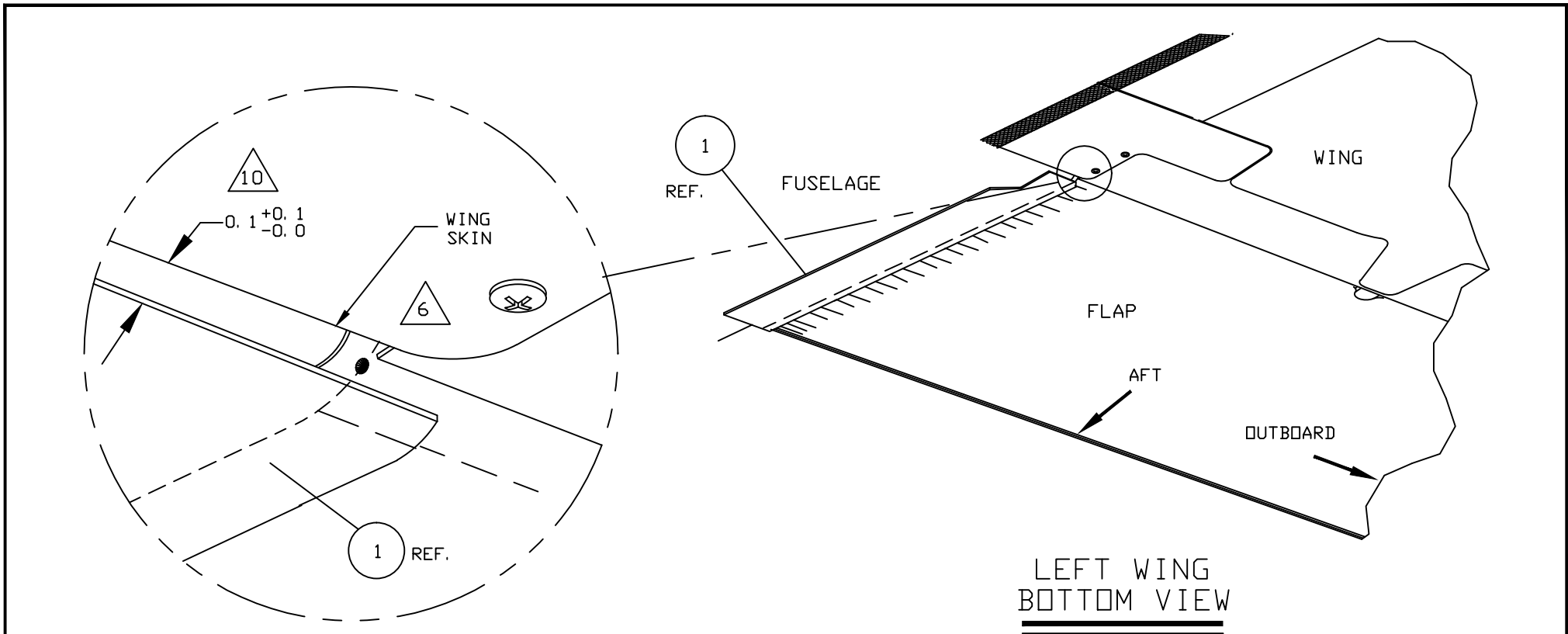

10 AFTER ALL HOLES HAVE BEEN DRILLED, CHECK TO SEE IF THE FORWARD EDGE OF ITEMS ① AND ② CLEAR THE AFT WING SKIN BY 0.1". IF NECESSARY TRIM ITEMS ① END ② TO GAIN CLEARANCE. CLECD IN PLACE AND HAND FORM FOR PROPER FIT. HAND FORMING IS CRITICAL TO MAKE SURE THERE IS NO PRESSURE FROM ITEMS ① AND ② AGAINST THE FUSELAGE. CAUTION: EXCESS PRESSURE COULD CAUSE FLAP COMPONENT STRAIN AND MOTOR BURNOUT.

6 POSITION ITEM ① AND ② ON THE BOTTOM OF THE FLAP APPROXIMATING THEIR LOCATION. ALIGN DRAWN PENCIL LINE FROM STEP 5 TO THE OUTBOARD SIDE OF ITEMS ① AND ②. THE LINE DRAWN ON ITEMS ① AND ② SHOULD FALL RIGHT OVER THE FACTORY INSTALLED RIVETS IN THE FLAP END RIB. ITEM ① AND ② SHOULD BE EVEN WITH THE BACK OF THE FLAP. THE RIVET LINE YOU DRAW IN STEP 1 SHOULD LINE UP WITH THE NEXT RIVET ON FLAP.

NOTES:

NEXT ASSY:		INSTALLATION GAP SEALS			
DRAWN BY: D. B.		D' SHANNON PRODUCTS, LTD			
ENGINEER: D. BRAUN					
CHECKED BY: D. B.					
TOLERANCES		DWG. No.	B6300D-5	REVISION	A
X_.10 .XXX_.01		SCALE: NONE	DATE 11/18/11	SH	8 OF 20
XX_.03 .XXX_.001					
ANGLES ±5%					
UNLESS STATED					

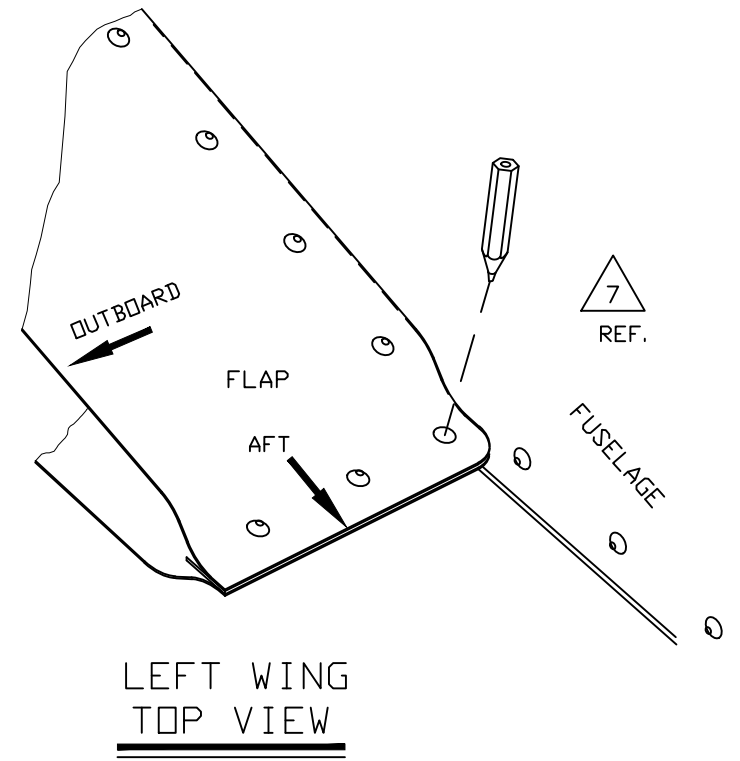
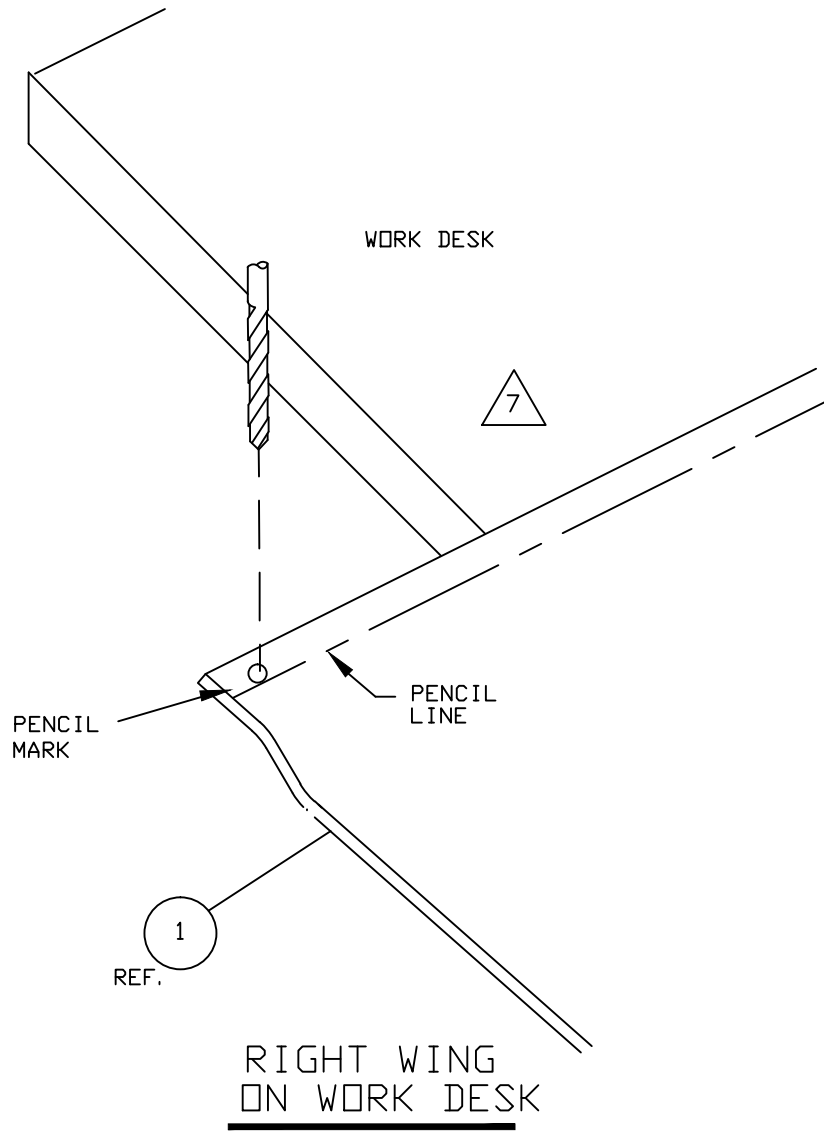

△ MARK THE PLACEMENT OF ITEMS ① AND ② INTO THE FLAP USING A SHARP PENCIL POINT THROUGH THE DRILLED OUT RIVET HOLE FROM STEP 2. YOU WILL NOTICE THAT THIS MARK WILL BE SLIGHTLY OFF THE DRAWN LINE BECAUSE THIS RIVET IS OFF LINE FROM ALL THE REST OF RIVETS. NOW USING A # 30 DRILL BIT, DRILL THROUGH THE PENCIL MARK INTO ITEMS ① AND ②. CLEAN HOLE AND CLECO TO FLAP.

NOTES:

NEXT ASSY: DRAWN BY: D. B. ENGINEER: D. BRAUN CHECKED BY: D. B.		INSTALLATION GAP SEALS	
TOLERANCES X_.10 .XXX_.01 XX_.03 .XXX_.001 ANGLES ±5% UNLESS STATED		D' SHANNON PRODUCTS, LTD	
DWG. No.	B6300D-5	REVISION	A
SCALE: NONE	DATE 11/18/11	SH	9 OF 20

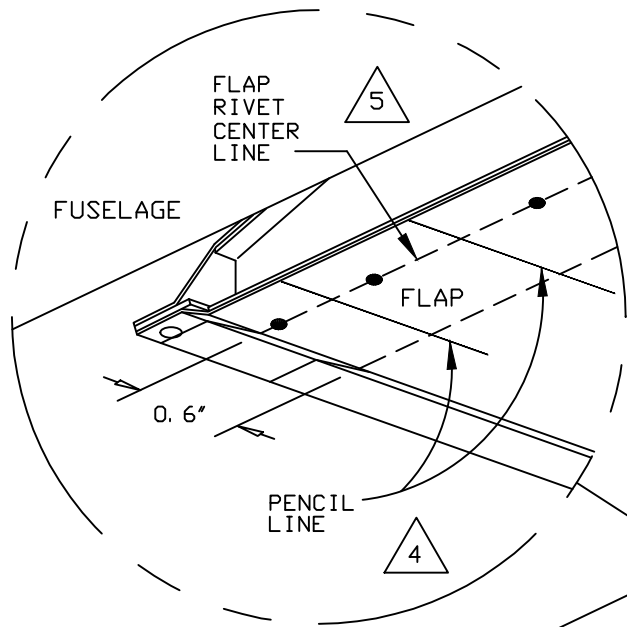

FUSELAGE

1

8

DRILL BIT

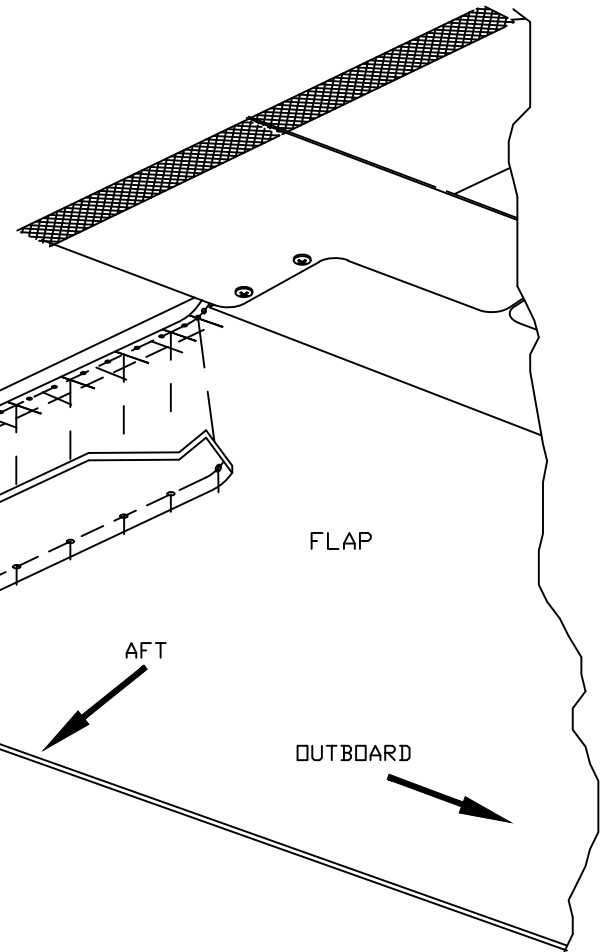

LEFT FLAP
BOTTOM VIEW
LOOKING UP

8 AT THIS POINT MAKE SURE THE BACK OF THE ITEMS ① AND ② ARE ALIGNED. DRILL ABOUT EVERY OTHER INTERSECTING LINE FROM STEPS 1 AND 4, USING A #30 DRILL BIT, THROUGH ITEMS ① AND ② INTO THE FLAP END RIB. YOU SHOULD BE DRILLING IN LINE AND IN BETWEEN EACH FACTORY INSTALLED RIVET USING THE INTERSECTING PENCIL GUIDE LINES FROM STEPS 1 AND 4.
NOTE: A SET NUMBER OF DRILLED OUT RIVETS CANNOT BE DETERMINED DUE TO THE DIFFERENCE IN THE NUMBER AND POSITION OF THE RIVETS ON THE FLAP. YOU SHOULD IDEALLY TRY TO STAY TO A MINIMUM OF 13 RIVETS, AND IDEALLY USE 14 RIVETS.

5 NEXT, DRAW A LINE CONNECTING THE RIVETS ON THE INBOARD BOTTOM OF THE FLAP. DRAW A SECOND LINE EXACTLY 0.6" PARALLEL TO THE RIVET LINE YOU HAVE JUST DRAWN. THIS SECOND LINE WILL ACT AS A GUIDE WHEN INSTALLING ITEM ① AND ②.

4 DRAW, ON THE BOTTOM OF THE FLAPS, 2" TO 3" PENCIL LINES INBOARD TO OUTBOARD BETWEEN EACH OF THE FACTORY RIVETS LOCATED ON THE INBOARD FLAP END RIB.

NOTES:

NEXT ASSY:
DRAWN BY: D. B.
ENGINEER: D. BRAUN
CHECKED BY: D. B.

INSTALLATION GAP SEALS

TOLERANCES
X_.10 .XXX_.01
XX_.03 .XXX_.001
ANGLES ±5%
UNLESS STATED

D' SHANNON PRODUCTS, LTD

DWG. No. B6300D-5 REVISION A

SCALE: NONE DATE 11/18/11 SH 10 OF 20

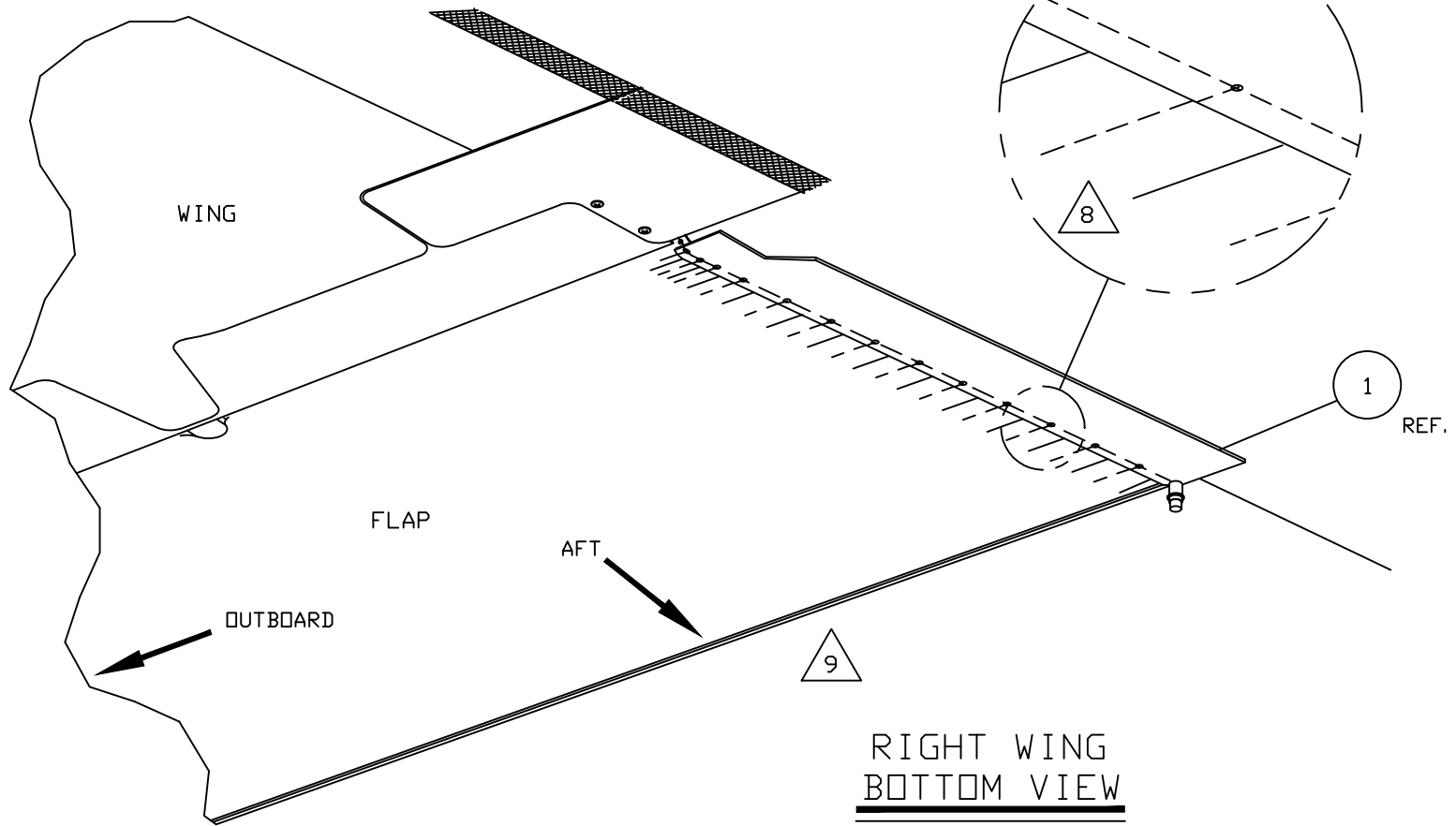

RIGHT WING
BOTTOM VIEW

- △ 9 YOU MAY NEED TO ADD AN ADDITIONAL RIVET AT THE END OR BEGINNING OF THE RIVET LINE FOR SAFETY. THE REASON BEING THAT THE TWO FLAPS WILL PROBABLY HAVE DIFFERENT RIVET PLACEMENTS OR CONFIGURATIONS.
- △ 8 AT THIS POINT MAKE SURE THE BACK OF THE ITEMS ① AND ② ARE ALIGNED. DRILL ABOUT EVERY OTHER INTERSECTING LINE FROM STEPS 1 AND 4, USING A #30 DRILL BIT, THROUGH ITEMS ① AND ② INTO THE FLAP END RIB. YOU SHOULD BE DRILLING IN LINE AND IN BETWEEN EACH FACTORY INSTALLED RIVET USING THE INTERSECTING PENCIL GUIDE LINES FROM STEPS 1 AND 4.
NOTE: A SET NUMBER OF DRILLED OUT RIVETS CANNOT BE DETERMINED DUE TO THE DIFFERENCE IN THE NUMBER AND POSITION OF THE RIVETS ON THE FLAP. YOU SHOULD IDEALLY TRY TO STAY TO A MINIMUM OF 13 RIVETS, AND IDEALLY USE 14 RIVETS.

NOTES:

NEXT ASSY: DRAWN BY: D. B. ENGINEER: D. BRAUN CHECKED BY: D. B.		INSTALLATION GAP SEALS	
TOLERANCES X_.10 .XXX_.01 XX_.03 .XXX_.001 ANGLES ±5% UNLESS STATED		D' SHANNON PRODUCTS, LTD	
DWG. No. B6300D-5	REVISION A		
SCALE: NONE	DATE 11/18/11	SH 11 OF 20	

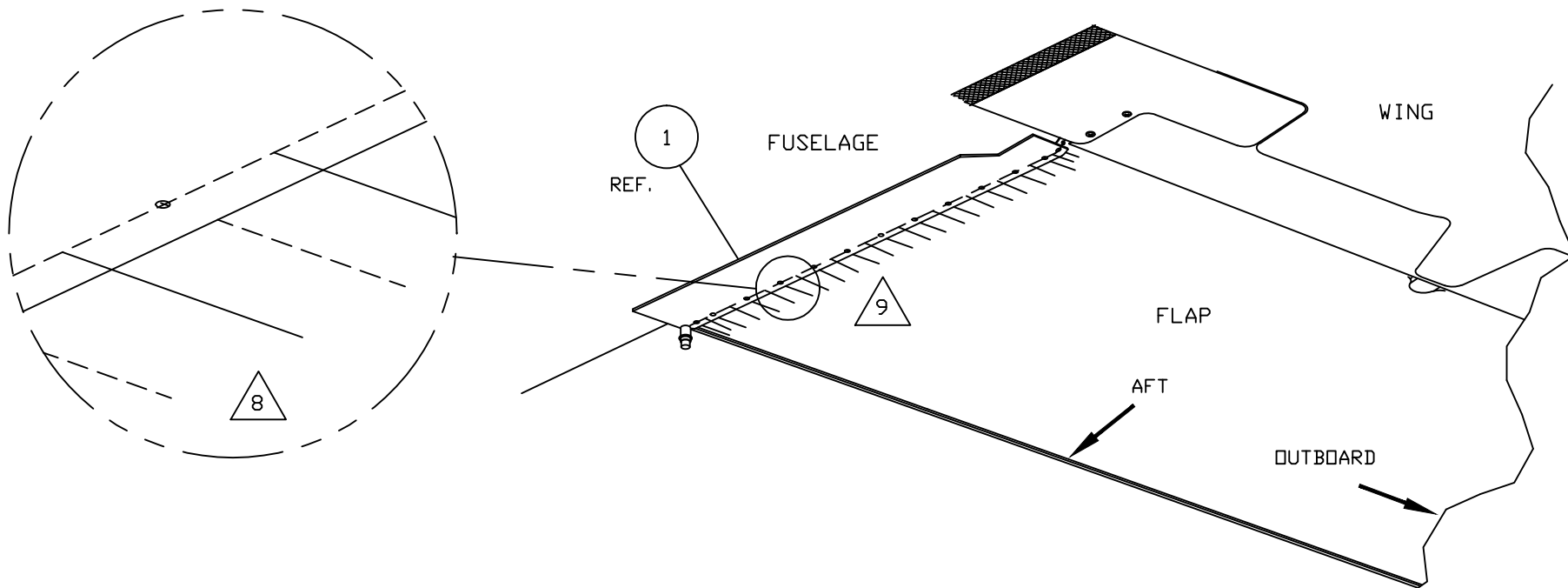

LEFT WING
BOTTOM VIEW

- △ 9 YOU MAY NEED TO ADD AN ADDITIONAL RIVET AT THE END OR BEGINNING OF THE RIVET LINE FOR SAFETY. THE REASON BEING THAT THE TWO FLAPS WILL PROBABLY HAVE DIFFERENT RIVET PLACEMENTS OR CONFIGURATIONS.
- △ 8 AT THIS POINT MAKE SURE THE BACK OF THE ITEMS ① AND ② ARE ALIGNED. DRILL ABOUT EVERY OTHER INTERSECTING LINE FROM STEPS 1 AND 4, USING A #30 DRILL BIT, THROUGH ITEMS ① AND ② INTO THE FLAP END RIB. YOU SHOULD BE DRILLING IN LINE AND IN BETWEEN EACH FACTORY INSTALLED RIVET USING THE INTERSECTING PENCIL GUIDE LINES FROM STEPS 1 AND 4.
NOTE: A SET NUMBER OF DRILLED OUT RIVETS CANNOT BE DETERMINED DUE TO THE DIFFERENCE IN THE NUMBER AND POSITION OF THE RIVETS ON THE FLAP. YOU SHOULD IDEALLY TRY TO STAY TO A MINIMUM OF 13 RIVETS, AND IDEALLY USE 14 RIVETS.

NOTES:

NEXT ASSY: DRAWN BY: D. B. ENGINEER: D. BRAUN CHECKED BY: D. B.		INSTALLATION GAP SEALS	
TOLERANCES X_.10 .XXX_.01 XX_.03 .XXX_.001 ANGLES ±5% UNLESS STATED		D' SHANNON PRODUCTS, LTD	
DWG. No.	B6300D-5	REVISION	A
SCALE: NONE	DATE 11/18/11	SH	12 OF 20

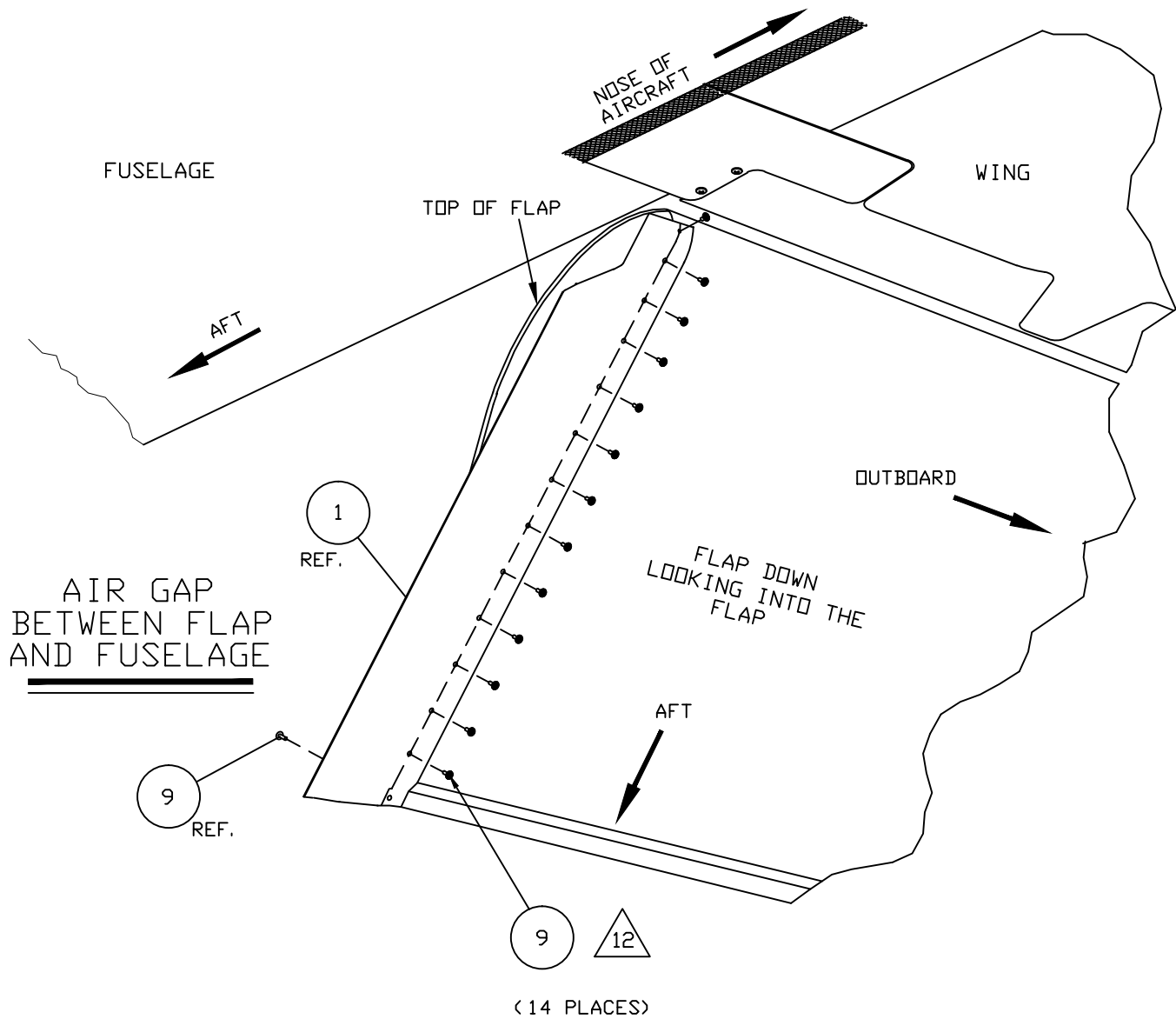

12 LOWER FLAP AND RIVET ITEMS ① AND ② INTO PLACE USING AN470AD4-4 RIVETS ITEM ⑨. RAISE FLAP AND VERIFY NO LOAD EXISTS BETWEEN ITEMS ① AND ② AND THE FUSELAGE. IF LOADED, ADJUST BY HAND FORMING ITEMS ① AND ②.

NOTES:

NEXT ASSY: DRAWN BY: D. B. ENGINEER: D. BRAUN CHECKED BY: D. B.		INSTALLATION GAP SEALS	
TOLERANCES X_.10 .XXX_.01 XX_.03 .XXX_.001 ANGLES ±5% UNLESS STATED		D' SHANNON PRODUCTS, LTD	
DWG. No.	B6300D-5	REVISION	A
SCALE: NONE	DATE 11/18/11	SH 13	OF 20

LEFT WING
TOP VIEW

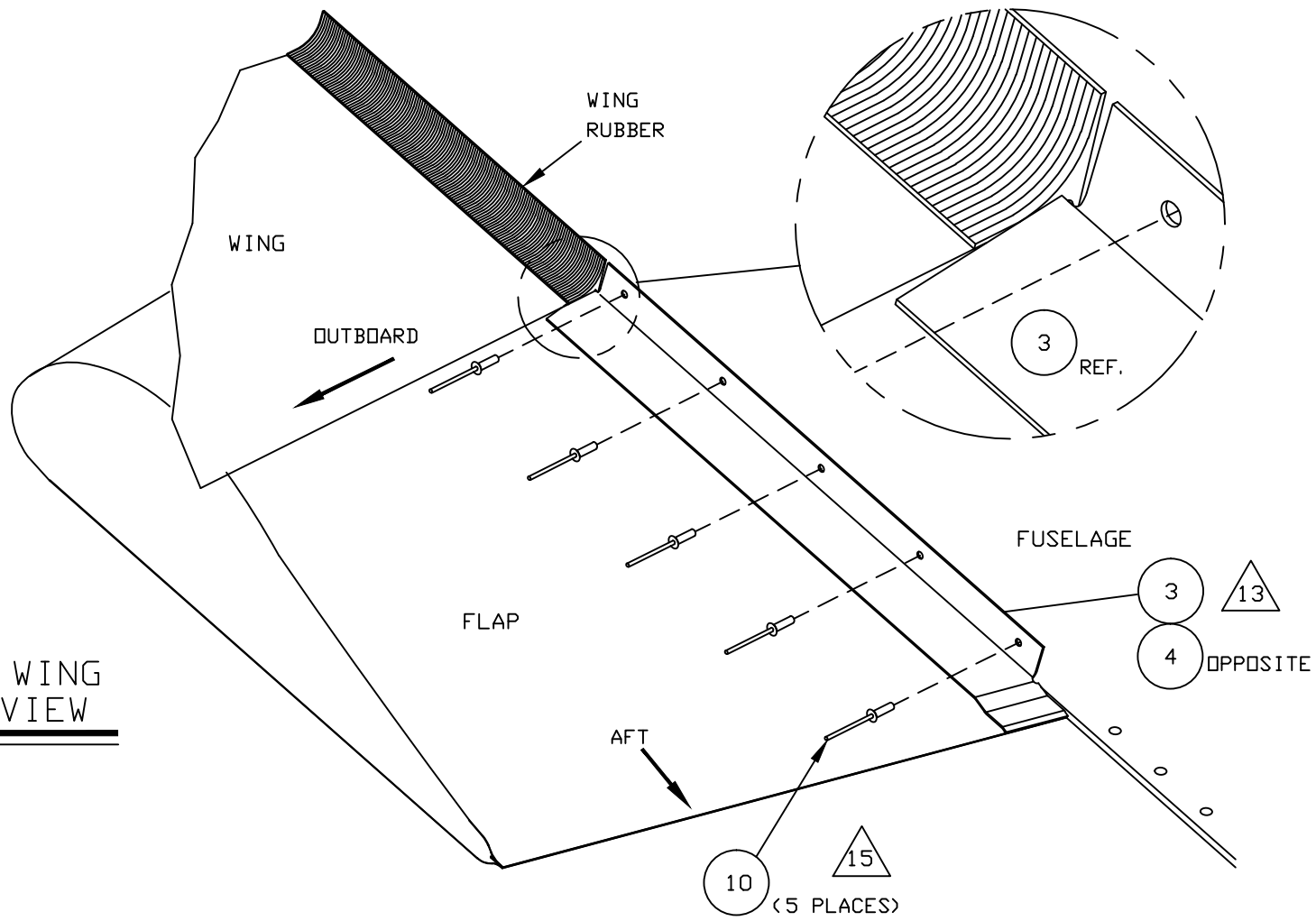

△15 ITEMS ③ AND ④ SHOULD HAVE NO TENSION AGAINST THE FLAP. HAND FORM IF NECESSARY. ONCE ALIGNED, USING A #30 DRILL BIT, DRILL 5 EVENLY SPACED HOLES. THE OUTER HOLE SHOULD HAVE PROPER EDGE DISTANCE. CLEAN HOLES, AND RIVET ITEMS ③ AND ④ USING AD44H ITEM ⑩ POP RIVETS.

△13 POSITION ITEMS ③ AND ④ APPROXIMATING THEIR LOCATION. THE AFT EDGE END WILL PROBABLY NEED TO BE JOGGLED SO THAT ITEMS ③ AND ④ MATCH THE EDGE AND CONTOUR OF THE TRAILING EDGE OF THE FLAP. TRIM THE FRONT OF ITEMS ③ AND ④ IF NEEDED.

NOTES:

NEXT ASSY: DRAWN BY: D. B. ENGINEER: D. BRAUN CHECKED BY: D. B.		INSTALLATION GAP SEALS	
TOLERANCES X_.10 .XXX_.01 XX_.03 .XXX_.001 ANGLES ±5% UNLESS STATED		D' SHANNON PRODUCTS, LTD	
DWG. No.	B6300D-5	REVISION	A
SCALE: NONE	DATE 11/18/11	SH 14 OF 20	

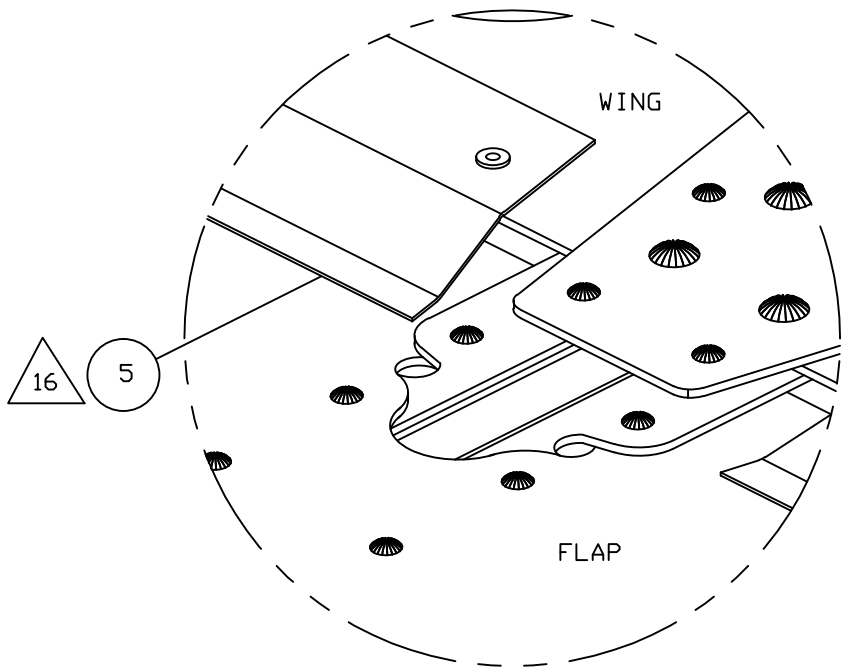

DETAIL "A"

FROM SHEET 3 OF 20
 GAP SEAL POSITION
 COMPARED TO THE FLAP HINGE.

△ 16 ITEM ⑤ IS MADE UP OF 6 PIECES (3 PIECES FOR EACH SIDE). EACH PIECE WILL HAVE TO BE TRIMMED FOR PROPER FIT. THIS IS DONE BECAUSE THERE ARE NO SET SIZE FOR THE FLAPS. EACH PIECE WILL BE HELD UP AGAINST THE WING AND TRIMMED. AN EXAMPLE OF THE POSITION OF ITEM ⑤ COMPARED TO THE AILERON HINGE IS SHOWN. IF NEEDED TRIM ITEM ⑤ TO FIT. IF TRIMMING IS NECESSARY MAKE SURE ITEM ⑤ DOESN'T INTERFERE WITH THE HINGE STRUCTURE ON THE FLAP.

NOTES:

NEXT ASSY:		INSTALLATION GAP SEALS	
DRAWN BY: D. B.		D' SHANNON PRODUCTS, LTD	
ENGINEER: D. BRAUN			
CHECKED BY: D. B.			
<u>TOLERANCES</u>		DWG. No. B6300D-5 REVISION A	
.X_.10 .XXX_.01		SCALE: NONE DATE 11/18/11 SH 15 OF 20	
.XX_.03 .XXX_.001			
ANGLES ±5%			
UNLESS STATED			

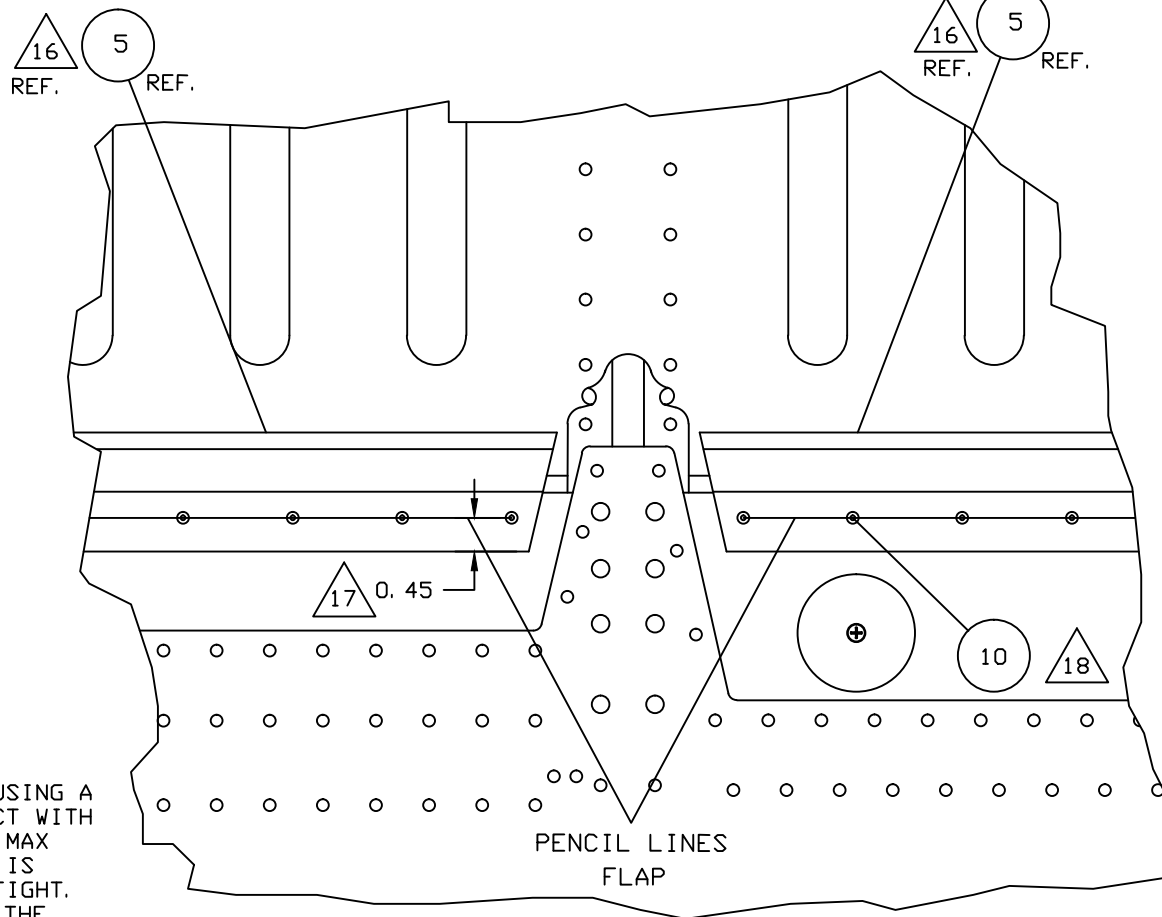

DETAIL "B"

FROM SHEET 3 OF 20

⑮ DRILL OUT ANY AND ALL OVAL HEAD RIVETS, USING A #27 DRILL BIT, THAT WILL COME INTO CONTACT WITH ANY PART OF GAP SEAL ITEM ⑤. USE CHERRY MAX CR3242-4-02 ITEM ⑮ OR EQUAL RIVET. IT IS CRITICAL THAT THESE RIVETS ARE FLUSH AND TIGHT. IF IN DOUBT USE EPOXY TO RETAIN TIGHTLY. THE HOLES MAY BE COUNTERSUNK OR DIMPLED. FILE THE OVER BURDEN RIVET HEADS TO FLUSH IF NECESSARY.

⑰ DRAW A LINE 0.45" FROM THE AFT EDGE OF ALL SIX PIECES OF ITEM ⑤. THIS LINE WILL BE DRAWN ON THE OPPOSITE SIDE OF THE TEFLON TAPE ALREADY INSTALLED. THE TEFLON TAPE WILL BE FACING THE FLAP. WITH THE DRAWN LINE AS YOUR GUIDE, USING A #30 DRILL BIT, DRILL THROUGH THE GAP SEAL AND INTO THE WING. THESE HOLES ARE TO BE NO MORE THAN 4" APPROX. THE HOLES START AT EACH END OF GAP SEAL ITEM ⑤. THE EDGE DISTANCE OF THE HOLES IS AT LEAST ONE AND ONE HALF TIMES THE SIZE OF THE HOLES. RIVET ITEMS ⑤ TO THE WING USING AD44H ITEM ⑩ POP RIVETS.

⑯ ITEM ⑤ IS MADE UP OF 6 PIECES (3 PIECES FOR EACH SIDE). EACH PIECE WILL HAVE TO BE TRIMMED FOR PROPER FIT. THIS IS DONE BECAUSE THERE ARE NO SET SIZE FOR THE FLAPS. EACH PIECE WILL BE HELD UP AGAINST THE WING AND TRIMMED. AN EXAMPLE OF THE POSITION OF ITEM ⑤ COMPARED TO THE AILERON HINGE IS SHOWN. IF NEEDED TRIM ITEM ⑤ TO FIT. IF TRIMMING IS NECESSARY MAKE SURE ITEM ⑤ DOESN'T INTERFERE WITH THE HINGE STRUCTURE ON THE FLAP.

NOTES:

NEXT ASSY: DRAWN BY: D. B. ENGINEER: D. BRAUN CHECKED BY: D. B.		INSTALLATION GAP SEALS	
TOLERANCES X_.10 .XXX_.01 XX_.03 .XXX_.001 ANGLES ±5% UNLESS STATED		D' SHANNON PRODUCTS, LTD	
DWG. No.	B6300D-5	REVISION	A
SCALE: NONE	DATE 11/18/11	SH	16 OF 20

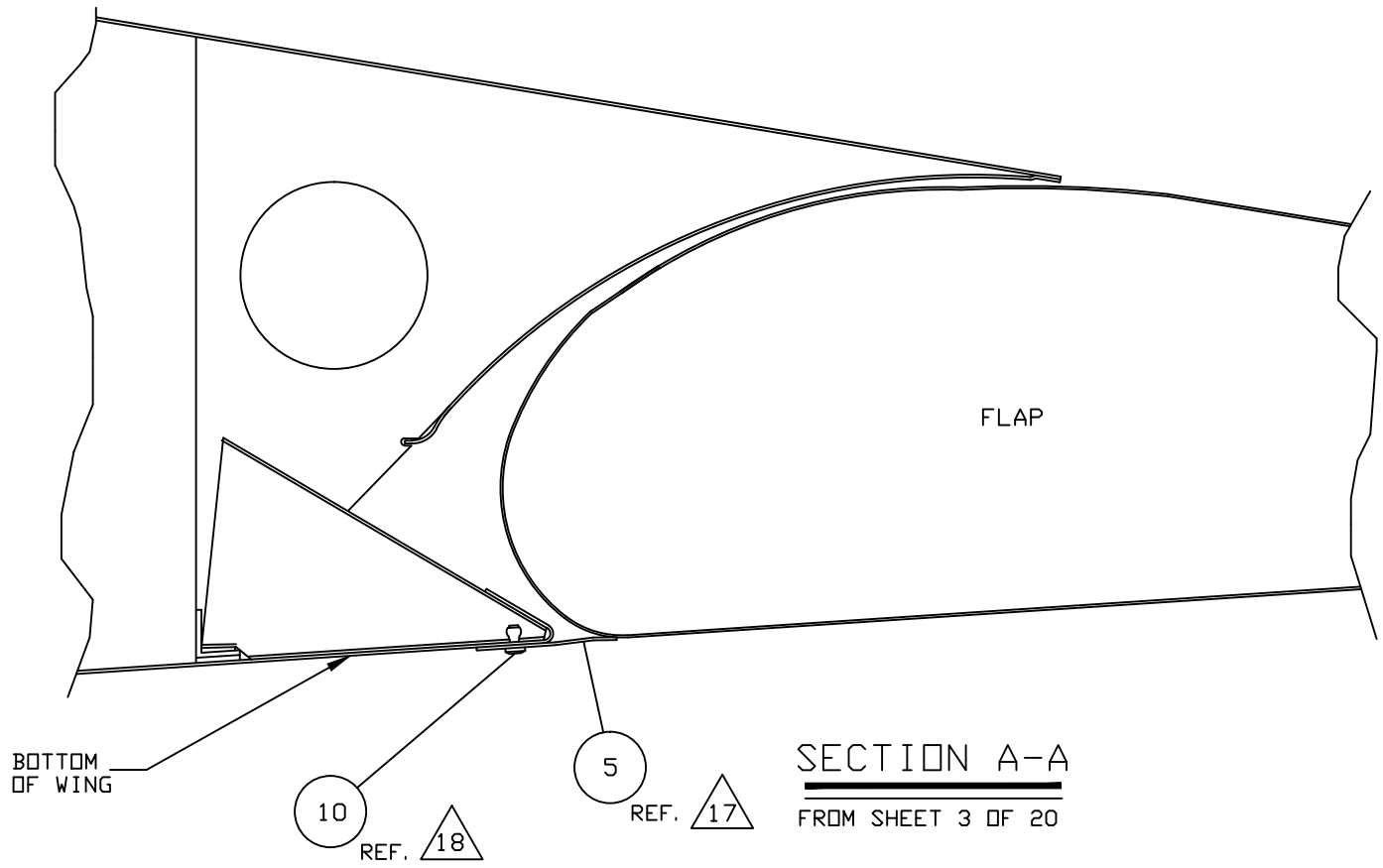

SECTION A-A
FROM SHEET 3 OF 20

- 18** DRILL OUT ANY AND ALL OVAL HEAD RIVETS, USING A #27 DRILL BIT, THAT WILL COME INTO CONTACT WITH ANY PART GAP SEAL ITEM **5**. USE CHERRY MAX CR3242-4-02 ITEM **15** OR EQUAL RIVET. IT IS CRITICAL THAT THESE RIVET ARE FLUSH AND TIGHT. IF IN DOUBT USE EPOXY TO RETAIN TIGHTLY. THE HOLES MAY BE COUNTERSUNK OR DIMPLED. FILE THE OVER BURDEN RIVET HEADS TO FLUSH IF NECESSARY.
- 17** DRAW A LINE 0.45" FROM THE AFT EDGE OF ALL SIX PIECES OF ITEM **5**. THIS LINE WILL BE DRAWN ON THE OPPOSITE SIDE OF THE TEFLON TAPE ALREADY INSTALLED. THE TEFLON TAPE WILL BE FACING THE FLAP. WITH THE DRAWN LINE AS YOUR GUIDE, USING A #30 DRILL BIT, DRILL THROUGH THE GAP SEAL AND INTO THE WING. THESE HOLES ARE TO BE NO MORE THAN 4" APPROX. THE HOLES START AT EACH END OF GAP SEAL ITEM **5**. THE EDGE DISTANCE OF THE HOLES IS AT LEAST ONE AND ONE HALF TIMES THE SIZE OF THE HOLES. RIVET ITEMS **5** TO THE WING USING AD44H ITEM **10** POP RIVETS.

NOTES:

NEXT ASSY:		INSTALLATION GAP SEALS			
DRAWN BY: D. B.		D' SHANNON PRODUCTS, LTD			
ENGINEER: D. BRAUN					
CHECKED BY: D. B.					
TOLERANCES		DWG. No.	B6300D-5	REVISION	A
X_.10 .XXX_.01		SCALE: NONE	DATE 11/18/11	SH 17	OF 20
XX_.03 .XXX_.001					
ANGLES ±5%					
UNLESS STATED					

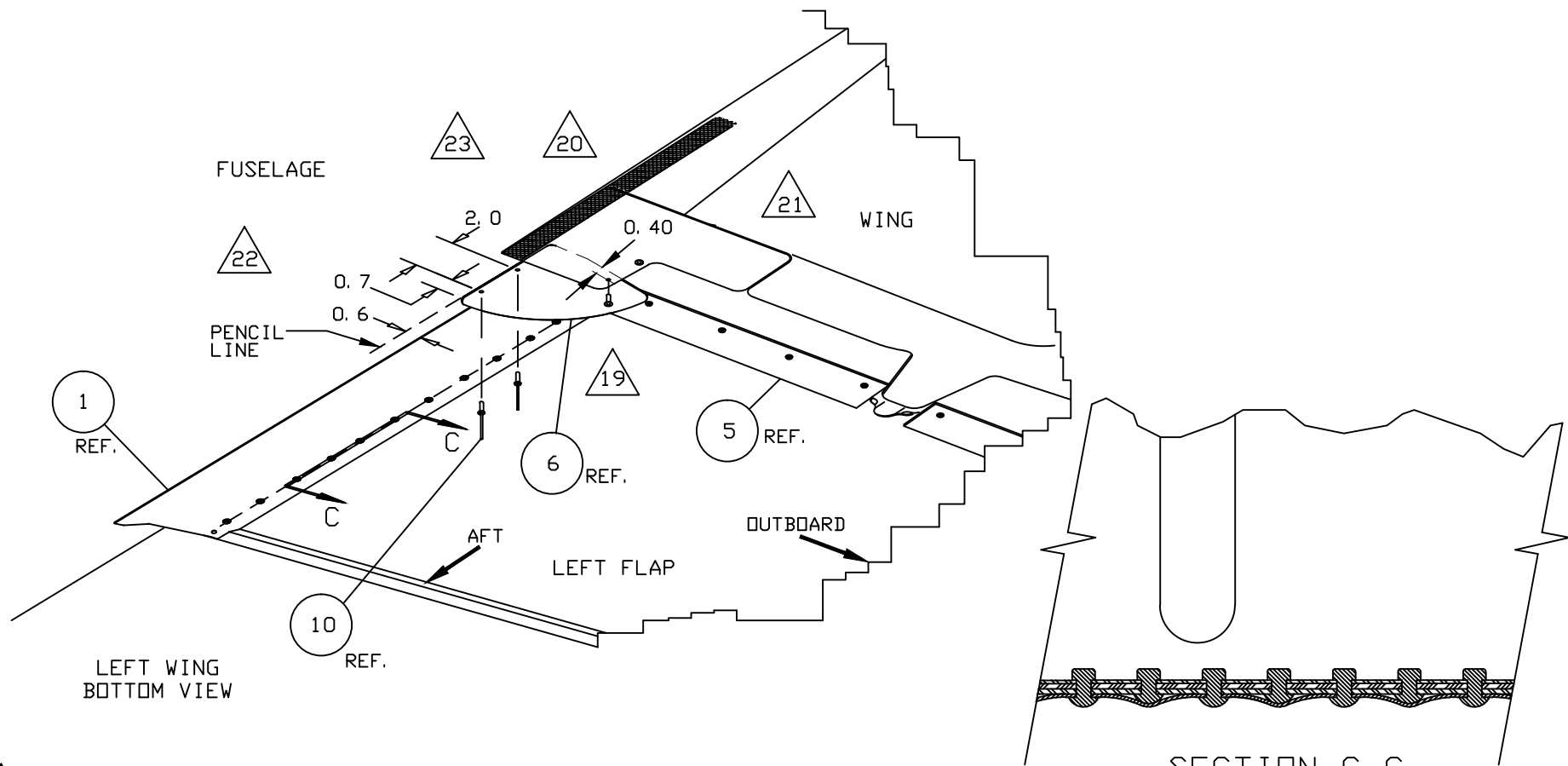

- △23 DRILL APPROXIMATELY 0.7" FROM THE AFT SIDE OF ITEMS ⑥ AND ⑦ USING A #30 DRILL BIT. MEASURE 2" FROM THE FIRST HOLE DRILLED. THIS IS WHERE THE SECOND HOLE SHOULD BE DRILLED. INSTALL AD44H RIVETS ITEM ⑩
- △22 USING A #21 DRILL BIT, DRILL THROUGH THE HOLE IN THE WING BOLT COVER PLATE AND INTO ITEMS ⑥ AND ⑦. REINSTALL THE SCREW.
- △21 TO DETERMINATE THE DEPTH IN WHICH ITEMS ⑥ AND ⑦ ARE TO GO UNDER THE WING BOLT COVER, INSERT ITEMS ⑥ AND ⑦ FORWARD UNTIL THE FORWARD EDGE OF ITEMS ⑥ AND ⑦ ARE APPROXIMATELY 0.4" FROM THE WING BOLT COVER SCREW.
- △20 DRAW A STRAIGHT LINE PARALLEL TO ITEMS ① AND ②. POSITION ITEMS ⑥ AND ⑦ APPROXIMATING THEIR LOCATION. LINE UP THESE ITEMS WITH THE 0.6" REFERENCE LINE YOU JUST DREW.
- △19 REMOVE REAR WING BOLT COVER SCREWS AS SHOWN ON DRAWING. MEASURE 0.6" FROM THE INBOARD SIDE OF ITEM ① AND ②

NOTES:

NEXT ASSY: DRAWN BY: D. B. ENGINEER: D. BRAUN CHECKED BY: D. B.		INSTALLATION GAP SEALS	
TOLERANCES X_.10 .XXX_.01 XX_.03 .XXX_.001 ANGLES ±5% UNLESS STATED		D' SHANNON PRODUCTS, LTD	
DWG. No.	B6300D-5	REVISION	A
SCALE: NONE	DATE 11/18/11	SH	18 OF 20

△27 REMOVE AILERON IN ACCORDANCE WITH BEECH SERVICE MANUAL. NOTE LOCATION OF AILERON HINGE STRUCTURE IN THE AILERON CAVITY. HOLES SHOULD NOT BE DRILLED THROUGH OR BETWEEN THE FLANGES INSIDE THE BACK OF THE AILERON CAVITY THAT HOLDS THE HINGE STRUCTURE TO THE WING. DRILL THROUGH ITEM ⑧ AND THE WING SKIN USING A #40 DRILL BIT ON THE RIVET LINES FROM STEP 24 (4" SPACING MAX.) MAKE SURE PROPER EDGE DISTANCE IS USED ON THE OUTER RIVETS. CLECO INTO PLACE. CLEAN HOLES, AND RIVET ITEM ⑧ INBOARD AND OUTBOARD ON THE AILERON USING AN470AD3-3 ITEM ⑬ UNIVERSAL HEAD RIVETS. ANY OVAL HEAD RIVETS THAT OBSTRUCT OR PREVENT THE FREE MOVEMENT OF THE AILERON SHOULD BE REPLACED WITH CR3242-4-02 ITEM ⑮ FLUSH HEAD CHERRY MAX RIVETS. IT IS CRITICAL THAT THESE RIVETS ARE FLUSH AND TIGHT. IF IN DOUBT USE EPXY TO RETAIN THE RIVETS TIGHTLY, COUNTERSINK OR DIMPLE IF PERMISSIBLE. FILE RIVET HEAD FLUSH IF NECESSARY. REINSTALL AILERON IN ACCORDANCE WITH BEECH SERVICE MANUAL AND CHECK FOR PROPER OPERATION WITH NO INTERFERENCE.

△26 POSITION ITEM ⑧ AT ITS APPROXIMATE LOCATION. ITEM ⑧ SHOULD BE INSTALLED IN RELATION TO THE SHAPE OF THE AILERON, NOT THE WING. ITEM ⑧ SHOULD BE PARALLEL TO THE AILERON. THIS IS DONE TO COMPENSATE FOR A LARGER OR DIFFERENT AILERONS. DEFLECT AILERON FULLY DOWN. THE SIDE OF ITEM ⑧ WITH THE TEFLON TAPE SHOULD MAKE CONTACT WITH THE AILERON. DEFLECT THE AILERON FULLY UP. THE TEFLON TAPE SIDE OF ITEM ⑧ SHOULD AGAIN JUST TOUCH THE AILERON AND SHOULD ONCE AGAIN SHOW NO PRESSURE. MAKE POSITION ADJUSTMENT TO ITEM ⑧ UNTIL THIS IS ACHIEVED. MARK THE FINAL POSITION OF THE LEADING EDGE OF ITEM ⑧ ON THE WING.

△24 POSITION ITEM ⑧ ON A WORKBENCH AND DRAW A PENCIL LINE 1/2" FROM THE FORWARD EDGE OF ITEM ⑧ THIS LINE WILL BE USED DURING INSTALLATION. THEN MEASURE AN ADDITIONAL 1.2" AND DRAW A PARALLEL PENCIL LINE.

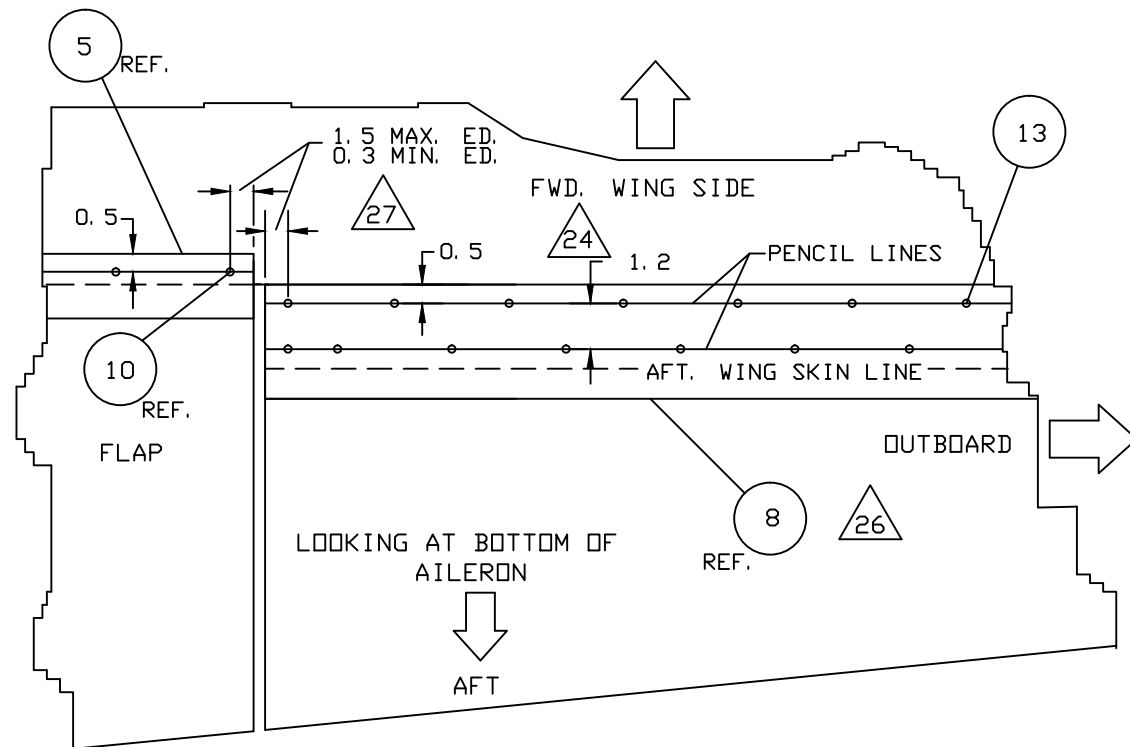

NOTES:

NEXT ASSY:		INSTALLATION GAP SEALS	
DRAWN BY: D. B.			
ENGINEER: D. BRAUN			
CHECKED BY: D. B.			
<u>TOLERANCES</u>		<i>D' SHANNON PRODUCTS, LTD</i>	
X_.10 .XXX_.01		DWG. No. B6300D-5 REVISION A	
XX_.03 .XXX_.001		SCALE: NONE DATE 11/18/11 SH 19 OF 20	
ANGLES ±5%			
UNLESS STATED			

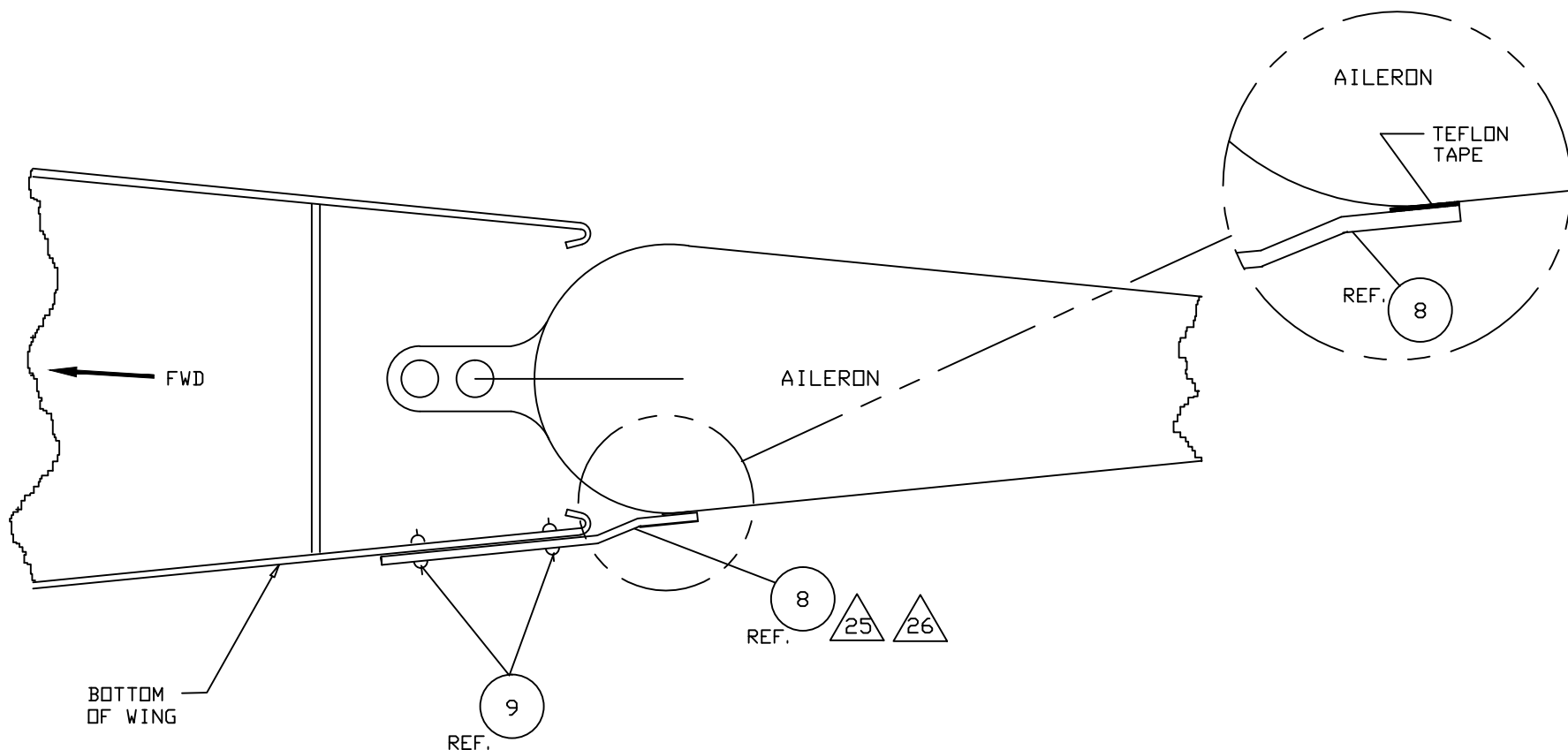

SECTION B-B
FROM SHEET 3 OF 20

△26 POSITION ITEM ⑧ AT IT'S APPROXIMATE LOCATION. ITEM ⑧ SHOULD BE INSTALLED IN RELATION TO THE SHAPE OF THE AILERON, NOT THE WING. ITEM ⑧ SHOULD BE PARALLEL TO THE AILERON. THIS IS DONE TO COMPENSATE FOR A LARGER OR DIFFERENT AILERONS. DEFLECT AILERON FULLY DOWN. THE SIDE OF ITEM ⑧ WITH THE TEFLON TAPE SHOULD MAKE CONTACT WITH THE AILERON. DEFLECT THE AILERON FULLY UP. THE TEFLON TAPE SIDE OF ITEM ⑧ SHOULD AGAIN JUST TOUCH THE AILERON AND SHOULD ONCE AGAIN SHOW NO PRESSURE. MAKE POSITION ADJUSTMENT TO ITEM ⑧ UNTIL THIS IS ACHIEVED. MARK THE FINAL POSITION OF THE LEADING EDGE OF ITEM ⑧ ON THE WING.

△25 IF NEEDED TRIM ITEM ⑧ TO FIT. IF TRIMMING IS NECESSARY MAKE SURE ITEM ⑧ DOESN'T INTERFERE WITH THE HINGE STRUCTURE ON THE AILERON.

NOTES:

NEXT ASSY: DRAWN BY: D. B. ENGINEER: D. BRAUN CHECKED BY: D. B.		INSTALLATION GAP SEALS	
TOLERANCES X_.10 .XXX_.01 XX_.03 .XXX_.001 ANGLES ±5% UNLESS STATED		D' SHANNON PRODUCTS, LTD	
DWG. No.	B6300D-5	REVISION	A
SCALE: NONE	DATE 11/18/11	SH	20 OF 20